

# DATA SHEET

## S4LFT0635/126

F-Theta  
standard - optical glass  
1064 nm



### outline drawing

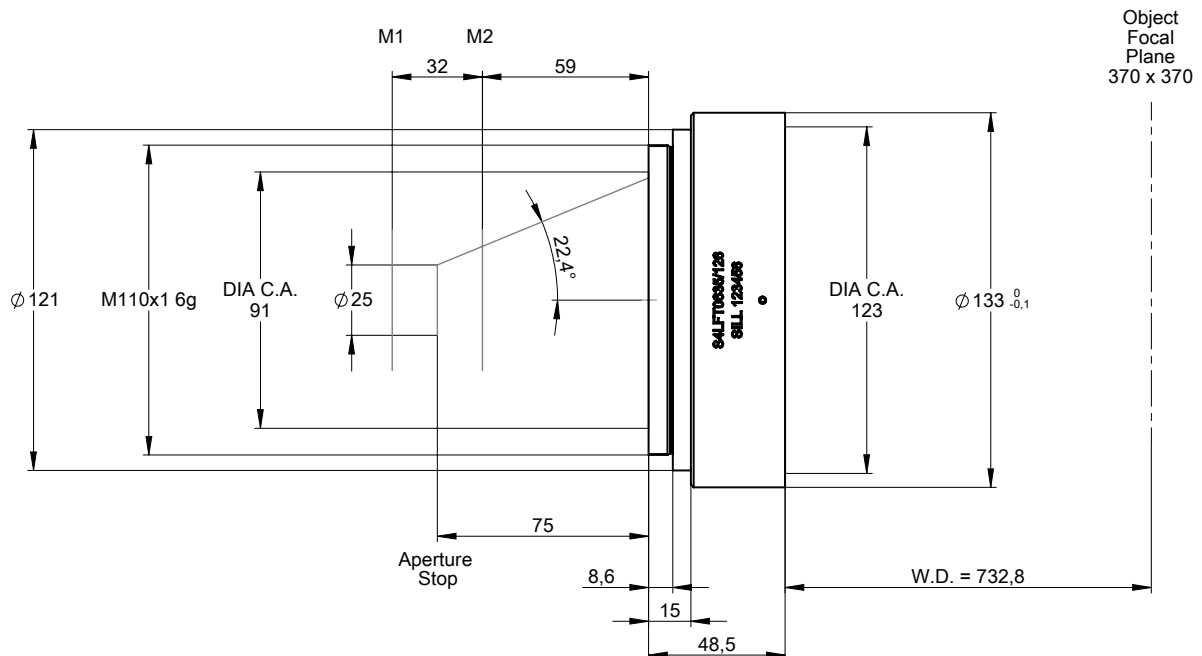

# DATA SHEET

## specifications

article number	S4LFT0635/126
design wavelength [nm]	1064
effective focal length [mm]	657.3
working distance [mm]	732.8
max. entrance beam-Ø [mm]	25.0
aperture stop distance [mm]	75.0
scan area for a 2 mirror system with mirror distance from lens housing for mirror 2 / mirror 1 [mm x mm]	370 x 370 59.0 / 91.0
max. telecentricity error [°]	16.3
total transmission [%]	> 98
absorption [ppm]	not specified
lens material	optical glass
LIDT (coating)	5.0 J/cm <sup>2</sup> per 1ns pulse at 50Hz
SP and USP usable	no
weight [kg]	1.35
cover glass	—
cleanliness	not specified

## spot

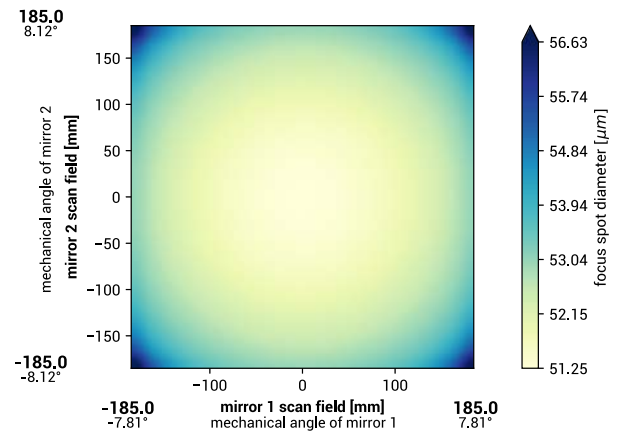

spot diameter at 86.5 % level for a Gaussian beam ( $M^2 = 1$ ) with 25.0 mm diameter at  $1/e^2$ , clipped at 25.0 mm field size and mirror distances as given above for a two mirror scan system

## back reflection positions

back reflections [mm] for 1064	
14.72	
26.69	
33.29	
68.61	
152.68	
355.55	
0.00	
0.00	
0.00	
0.00	

## remarks

The stated values are based on a vignetting of less than 1 %.

Effective focal length and working distance have a tolerance of +/- 1.5 %.

Absorption tolerance +/- 25 %. Absorption may increase. Correct cleaning establishes original condition.